A decorative graphic on the left side of the page, featuring a large dashed circle, a solid blue circle, and several overlapping curved lines in blue and grey.

Product Manual

Barracuda LP Series SATA

ST32000542AS

ST31500541AS

ST31000520AS

100564361
Rev. C
September 2009

Revision history

Revision	Date	Sheets affected or comments
Rev. A	04/16/09	Initial release.
Rev. B	06/08/09	4 & 11.
Rev. C	09/01/09	28. (add command - write uncorrectable = 45h); 11. (DC pwr req. update Idle Watts);1, 3, 8-9, 11, 14, 22 & 28. (remove 500GB model); 28. (Word 75 & 81 edit code);5. (corrected Non-Op shock value)

Copyright © 2009 Seagate Technology LLC. All rights reserved. Printed in U.S.A.

Publication number: 100564361, Rev. C September 2009

Seagate, Seagate Technology and the Wave logo are registered trademarks of Seagate Technology LLC in the United States and/or other countries. Barracuda LP Series, SeaTools and SeaTDD are either trademarks or registered trademarks of Seagate Technology LLC or one of its affiliated companies in the United States and/or other countries. All other trademarks or registered trademarks are the property of their respective owners.

When referring to hard drive capacity, one gigabyte, or GB, equals one billion bytes and one terabyte, or TB, equals one trillion bytes. Your computer's operating system may use a different standard of measurement and report a lower capacity. In addition, some of the listed capacity is used for formatting and other functions, and thus will not be available for data storage. Seagate reserves the right to change, without notice, product offerings or specifications.

Contents

1.0	Introduction	1
1.1	About the Serial ATA interface	2
2.0	Drive specifications	3
2.1	Formatted capacity	8
2.1.1	LBA mode	8
2.2	Default logical geometry	8
2.3	Recording and interface technology	8
2.4	Physical characteristics	9
2.5	Access time	9
2.6	Start/stop times	9
2.7	Power specifications	10
2.7.1	Power consumption	10
2.7.2	Conducted noise	12
2.7.3	Voltage tolerance	12
2.7.4	Power-management modes	13
2.8	Environmental specifications	14
2.8.1	Ambient temperature	14
2.8.2	Temperature gradient	14
2.8.3	Humidity	14
2.8.4	Altitude	14
2.8.5	Shock	15
2.8.6	Vibration	15
2.9	Acoustics	16
2.9.1	Test for Prominent Discrete Tones (PDTs)	16
2.10	Electromagnetic immunity	16
2.11	Reliability	17
2.11.1	Annualized Failure Rate (AFR) and Mean Time Between Failures (MTBF)	17
2.12	Agency certification	17
2.12.1	Safety certification	17
2.12.2	Electromagnetic compatibility	17
2.12.3	FCC verification	18
2.13	Environmental protection	19
2.13.1	European Union Restriction of Hazardous Substances (RoHS) Directive	19
2.13.2	China Restriction of Hazardous Substances (RoHS) Directive	19
2.14	Corrosive environment	19
3.0	Configuring and mounting the drive	20
3.1	Handling and static-discharge precautions	20
3.2	Configuring the drive	21
3.3	Serial ATA cables and connectors	21
3.4	Drive mounting	22
4.0	Serial ATA (SATA) interface	23
4.1	Hot-Plug compatibility	23
4.2	Serial ATA device plug connector pin definitions	24
4.3	Supported ATA commands	25
4.3.1	Identify Device command	27
4.3.2	Set Features command	31
4.3.3	S.M.A.R.T. commands	32
5.0	Seagate Technology support services	33

List of Figures

Figure 1.	Serial ATA connectors	21
Figure 2.	Attaching SATA cabling	21
Figure 3.	Mounting dimensions (2.0, 1.5 and 1.0 TB models).	22

1.0 Introduction

This manual describes the functional, mechanical and interface specifications for the following Seagate Barracuda® LP Series model drives:

ST32000542AS

ST31500541AS

ST31000520AS

These drives provide the following key features:

- 5,900 RPM spindle speed.
- High instantaneous (burst) data-transfer rates (up to 300 Mbytes per second).
- Perpendicular recording technology provides the drives with increased areal density.
- State-of-the-art cache and on-the-fly error-correction algorithms.
- Native Command Queuing with command ordering to increase performance in demanding applications.
- Full-track multiple-sector transfer capability without local processor intervention.
- Quiet operation.
- Compliant with RoHS requirements in China and Europe.
- SeaTools diagnostic software performs a drive self-test that eliminates unnecessary drive returns.
- Support for S.M.A.R.T. drive monitoring and reporting.
- Supports latching SATA cables and connectors.
- Worldwide Name (WWN) capability uniquely identifies the drive.

1.1 About the Serial ATA interface

The Serial ATA interface provides several advantages over the traditional (parallel) ATA interface. The primary advantages include:

- Easy installation and configuration with true plug-and-play connectivity. It is not necessary to set any jumpers or other configuration options.
- Thinner and more flexible cabling for improved enclosure airflow and ease of installation.
- Scalability to higher performance levels.

In addition, Serial ATA makes the transition from parallel ATA easy by providing legacy software support. Serial ATA was designed to allow you to install a Serial ATA host adapter and Serial ATA disc drive in your current system and expect all of your existing applications to work as normal.

The Serial ATA interface connects each disc drive in a point-to-point configuration with the Serial ATA host adapter. There is no master/slave relationship with Serial ATA devices like there is with parallel ATA. If two drives are attached on one Serial ATA host adapter, the host operating system views the two devices as if they were both “masters” on two separate ports. This essentially means both drives behave as if they are Device 0 (master) devices.

Note. The host adapter may, optionally, emulate a master/slave environment to host software where two devices on separate Serial ATA ports are represented to host software as a Device 0 (master) and Device 1 (slave) accessed at the same set of host bus addresses. A host adapter that emulates a master/slave environment manages two sets of shadow registers. This is not a typical Serial ATA environment.

The Serial ATA host adapter and drive share the function of emulating parallel ATA device behavior to provide backward compatibility with existing host systems and software. The Command and Control Block registers, PIO and DMA data transfers, resets, and interrupts are all emulated.

The Serial ATA host adapter contains a set of registers that shadow the contents of the traditional device registers, referred to as the Shadow Register Block. All Serial ATA devices behave like Device 0 devices. For additional information about how Serial ATA emulates parallel ATA, refer to the “Serial ATA International Organization: Serial ATA Revision 2.6”. The specification can be downloaded from www.sata-io.org.

2.0 Drive specifications

Unless otherwise noted, all specifications are measured under ambient conditions, at 25°C, and nominal power. For convenience, the phrases *the drive* and *this drive* are used throughout this manual to indicate the following drive models:

ST32000542AS

ST31500541AS

ST31000520AS

Specification summary tables

The specifications listed in the following tables are for quick reference. For details on specification measurement or definition, see the appropriate section of this manual.

Table 1: Drive specifications summary for 2000 and 1500 Gbyte models

Drive specification	ST32000542AS	ST31500541AS
Formatted capacity (512 bytes/sector)*	2000 Gbytes	1500 Gbytes
Guaranteed sectors	3,907,029,168	2,930,277,168
Heads	8	
Discs	4	
Bytes per sector	512	
Default sectors per track	63	
Default read/write heads	16	
Default cylinders	16,383	
Recording density	1417 kbits/in max	
Track density	236 ktracks/in avg	
Areal density	341.5 Gbits/in ² avg	
Spindle speed	5,900 RPM	
Internal data transfer rate	1285 Mbits/sec max	
Sustained data transfer rate OD	95 Mbytes/sec max	
I/O data-transfer rate	300 Mbytes/sec max	
ATA data-transfer modes supported	PIO modes 0–4 Multiword DMA modes 0–2 Ultra DMA modes 0–6	
Cache buffer	32 Mbytes	
Height (max)	26.1 mm (1.028 inches)	
Width (max)	101.85 mm (4.010 inches)	
Length (max)	146.99 mm (5.787 inches)	
Weight (typical)	655 grams (1.444 lb.)	
Average latency	5.1 msec	
Power-on to ready	<13 sec typical	
Standby to ready	<12 sec typical	
Track-to-track seek time	<1.0 msec typical read; <1.2 msec typical write	
Average read	<16.0 msec typical	
Average write	<16.0 msec typical	
Startup current (typical) 12V (peak)	2.0 amps	
Voltage tolerance (including noise)	5V ± 5% 12V ± 10%	
Operating temperature (Drive Case temperature)	0° to 60°C	
Nonoperating temperature (Ambient)	–40° to 70°C	
Temperature gradient (max)	20°C per hour max (operating) 30°C per hour max (nonoperating)	
Relative humidity	5% to 90% (operating) 5% to 95% (nonoperating)	
Relative humidity gradient	30% per hour max	
Wet bulb temperature (max)	37.7°C max (operating) 40.0°C max (nonoperating)	
Altitude, operating	–60.96 m to 3,048 m (–200 ft. to 10,000+ ft.)	
Altitude, nonoperating (below mean sea level, max)	–60.96 m to 12,192 m (–200 ft. to 40,000+ ft.)	

Drive specification	ST32000542AS	ST31500541AS
Operational Shock	70 Gs at 2 msec max	
Non-Operational Shock	300 Gs at 2 msec max	
Vibration, operating	5–350 Hz: 0.50 Gs 350–500 Hz: 0.25 Gs	
Vibration, nonoperating	5–350 Hz: 5.0 Gs 350–500 Hz: 2.0 Gs	
Drive acoustics, sound power		
Idle**	2.5 bels (typical) 2.6 bels (max)	
Seek Profile	2.6 bels (typical) 2.8 bels (max)	
Nonrecoverable read errors	1 per 10 ¹⁴ bits read	
Annualized Failure Rate (AFR)	0.32%	
Warranty	To determine the warranty for a specific drive, use a web browser to access the following web page: support.seagate.com/customer/warranty_validation.jsp From this page, click on the “Verify Your Warranty” link. You will be asked to provide the drive serial number, model number (or part number) and country of purchase. The system will display the warranty information for your drive.	
Contact start-stop cycles	50,000 at 25°C, 50% rel. humidity	
Supports Hotplug operation per the Serial ATA Revision 2.6 specification	Yes	

*One Gbyte equals one billion bytes when referring to hard drive capacity. Accessible capacity may vary depending on operating environment and formatting.

**During periods of drive idle, some offline activity may occur according to the S.M.A.R.T. specification, which may increase acoustic and power to operational levels.

Table 2: Drive specifications summary for 1000 Gbyte models

Drive specification	ST31000520AS
Formatted capacity (512 bytes/sector)*	1000 Gbytes
Guaranteed sectors	1,953,525,168
Heads	4
Discs	2
Bytes per sector	512
Default sectors per track	63
Default read/write heads	16
Default cylinders	16,383
Recording density	1417 kbits/in max
Track density	236 ktracks/in avg
Areal density	341.5 Gbits/in ² avg
Spindle speed	5,900 RPM
Internal data transfer rate	1285 Mbits/sec max
Sustained data transfer rate OD	95 Mbytes/sec max
I/O data-transfer rate	300 Mbytes/sec max
ATA data-transfer modes supported	PIO modes 0–4 Multiword DMA modes 0–2 Ultra DMA modes 0–6
Cache buffer	32 Mbytes
Height (max)	26.1 mm (1.028 inches)
Width (max)	101.85 mm (4.010 inches)
Length (max)	146.99 mm (5.787 inches)
Weight (typical)	622 grams (1.371 lb.)
Average latency	5.1 msec
Power-on to ready	<12 sec typical
Standby to ready	<6 sec typical
Track-to-track seek time	<1.0 msec typical read; <1.2 msec typical write
Average read	<16.0 msec typical
Average write	<16.0 msec typical
Startup current (typical) 12V (peak)	2.0 amps
Voltage tolerance (including noise)	5V ± 5% 12V ± 10%
Operating temperature (Drive Case temperature)	0° to 60°C
Nonoperating temperature (Ambient)	–40° to 70°C
Temperature gradient (max)	20°C per hour max (operating) 30°C per hour max (nonoperating)
Relative humidity	5% to 90% (operating) 5% to 95% (nonoperating)
Relative humidity gradient	30% per hour max
Wet bulb temperature (max)	37.7°C max (operating) 40.0°C max (nonoperating)
Altitude, operating	–60.96 m to 3,048 m (–200 ft. to 10,000+ ft.)
Altitude, nonoperating (below mean sea level, max)	–60.96 m to 12,192 m (–200 ft. to 40,000+ ft.)

Drive specification	ST31000520AS
Operational Shock	70 Gs at 2 msec max
Non-Operational Shock	350 Gs at 2 msec max
Vibration, operating	5–350 Hz: 0.50 Gs 350–500 Hz: 0.25 Gs
Vibration, nonoperating	5–350 Hz: 5.0 Gs 350–500 Hz: 2.0 Gs
Drive acoustics, sound power	
Idle**	1.9 bels (typical) 2.1 bels (max)
Seek Profile	2.0 bels (typical) 2.2 bels (max)
Nonrecoverable read errors	1 per 10 ¹⁴ bits read
Annualized Failure Rate (AFR)	0.32%
Warranty	To determine the warranty for a specific drive, use a web browser to access the following web page: support.seagate.com/customer/warranty_validation.jsp From this page, click on the “Verify Your Warranty” link. You will be asked to provide the drive serial number, model number (or part number) and country of purchase. The system will display the warranty information for your drive.
Contact start-stop cycles	50,000 at 25°C, 50% rel. humidity
Supports Hotplug operation per the Serial ATA Revision 2.6 specification	Yes

*One Gbyte equals one billion bytes when referring to hard drive capacity. Accessible capacity may vary depending on operating environment and formatting.

**During periods of drive idle, some offline activity may occur according to the S.M.A.R.T. specification, which may increase acoustic and power to operational levels.

2.1 Formatted capacity

Model	Formatted capacity*	Guaranteed sectors	Bytes per sector
ST32000542AS	2000 Gbytes	3,907,029,168	512
ST31500541AS	1500 Gbytes	2,930,277,168	
ST31000520AS	1000 Gbytes	1,953,525,168	

*One Gbyte equals one billion bytes when referring to hard drive capacity. Accessible capacity may vary depending on operating environment and formatting.

2.1.1 LBA mode

When addressing these drives in LBA mode, all blocks (sectors) are consecutively numbered from 0 to $n-1$, where n is the number of guaranteed sectors as defined above.

See Section 4.3.1, "Identify Device command" (words 60-61 and 100-103) for additional information about 48-bit addressing support of drives with capacities over 137 Gbytes.

2.2 Default logical geometry

Cylinders	Read/write heads	Sectors per track
16,383	16	63

LBA mode

When addressing these drives in LBA mode, all blocks (sectors) are consecutively numbered from 0 to $n-1$, where n is the number of guaranteed sectors as defined above.

2.3 Recording and interface technology

Interface	Serial ATA (SATA)
Recording method	Perpendicular
Recording density (kbits/inch max)	1417 kbits/in max
Track density (ktracks/inch avg)	236 ktracks/in avg
Areal density (Gbits/inch ² avg)	341.5 Gbits/in ² avg
Spindle speed (RPM)	5,900 +/- 0.2%
Internal data transfer rate (Mbits/sec max)	1285 Mbits/sec max
Sustained data transfer rate (Mbytes/sec max)	95 Mbytes/sec max
I/O data-transfer rate (Mbytes/sec max)	300 (Mbytes/sec max)

2.4 Physical characteristics

	ST32000542AS and ST31500541AS	ST31000520AS
Maximum height	26.1 mm (1.028 inches)	
Maximum width	101.85 mm (4.010 inches)	
Maximum length	146.99 mm (5.787 inches)	
Typical weight	655 grams (1.444 lb.)	622 grams (1.371lb.)
Cache buffer	32 Mbytes (16,384 kbytes)	

2.5 Access time

Access time measurements are taken with nominal power at 25°C ambient temperature. All times are measured using drive diagnostics. The specifications in the table below are defined as follows:

- Track-to-track access time is an average of all possible single-track seeks in both directions.
- Average access time is a true statistical random average of at least 5,000 measurements of seeks between random tracks, less overhead.

Typical access times (msec)	Read	Write
Track-to-track	<1.0	<1.2
Average	<16.0	<16.0

Note. These drives are designed to consistently meet the seek times represented in this manual. Physical seeks, regardless of mode (such as track-to-track and average), are expected to meet the noted values. However, due to the manner in which these drives are formatted, benchmark tests that include command overhead or measure logical seeks may produce results that vary from these specifications.

2.6 Start/stop times

	2000 and 1500 GB models	1000 GB models
Power-on to Ready (sec)	<10.0 (typical)	<8.0 (typical)
Standby to Ready (sec)	<12.0 (typical)	<6.0 (typical)
Ready to spindle stop (sec)	10 (max)	

2.7 Power specifications

The drive receives DC power (+5V or +12V) through a native SATA power connector. See Figure 2 on page 21.

2.7.1 Power consumption

Power requirements for the drives are listed in the table on page 9. Typical power measurements are based on an average of drives tested, under nominal conditions, using 5.0V and 12.0V input voltage at 25°C ambient temperature.

- **Spinup power**

Spinup power is measured from the time of power-on to the time that the drive spindle reaches operating speed.

- **Read/write power and current**

Read/write power is measured with the heads on track, based on a 16-sector write followed by a 32-msec delay, then a 16-sector read followed by a 32-msec delay.

- **Operating power and current**

Operating power is measured using 40 percent random seeks, 40 percent read/write mode (1 write for each 10 reads) and 20 percent drive idle mode.

- **Idle mode power**

Idle mode power is measured with the drive up to speed, with servo electronics active and with the heads in a random track location.

- **Standby mode**

During Standby mode, the drive accepts commands, but the drive is not spinning, and the servo and read/write electronics are in power-down mode.

Table 3: DC power requirements

Power dissipation (2TB and 1.5TB models)	Avg (watts 25° C)	Avg 5V typ amps	Avg 12V typ amps
Spinup	—	—	2.0 (peak)
Idle* †	4.30	0.168	0.337
Operating (average)	6.80	0.360	0.420
Standby	0.500	0.350	0.010
Sleep	0.500	0.350	0.010

Power dissipation (1TB models)	Avg (watts 25° C)	Avg 5V typ amps	Avg 12V typ amps
Spinup	—	—	2.0 (peak)
Idle* †	3.00	0.239	0.216
Operating (average)	5.70	0.335	0.350
Standby	0.321	0.225	0.096
Sleep	0.321	0.225	0.096

*During periods of drive idle, some offline activity may occur according to the S.M.A.R.T. specification, which may increase acoustic and power to operational levels.

†5W IDLE with DIPLM Enabled

Note. Drive supports PHY layer power management. When enabled, a power savings of ~300mw can be achieved in Idle, Standby and Sleep modes.

2.7.1.1 Typical current profiles

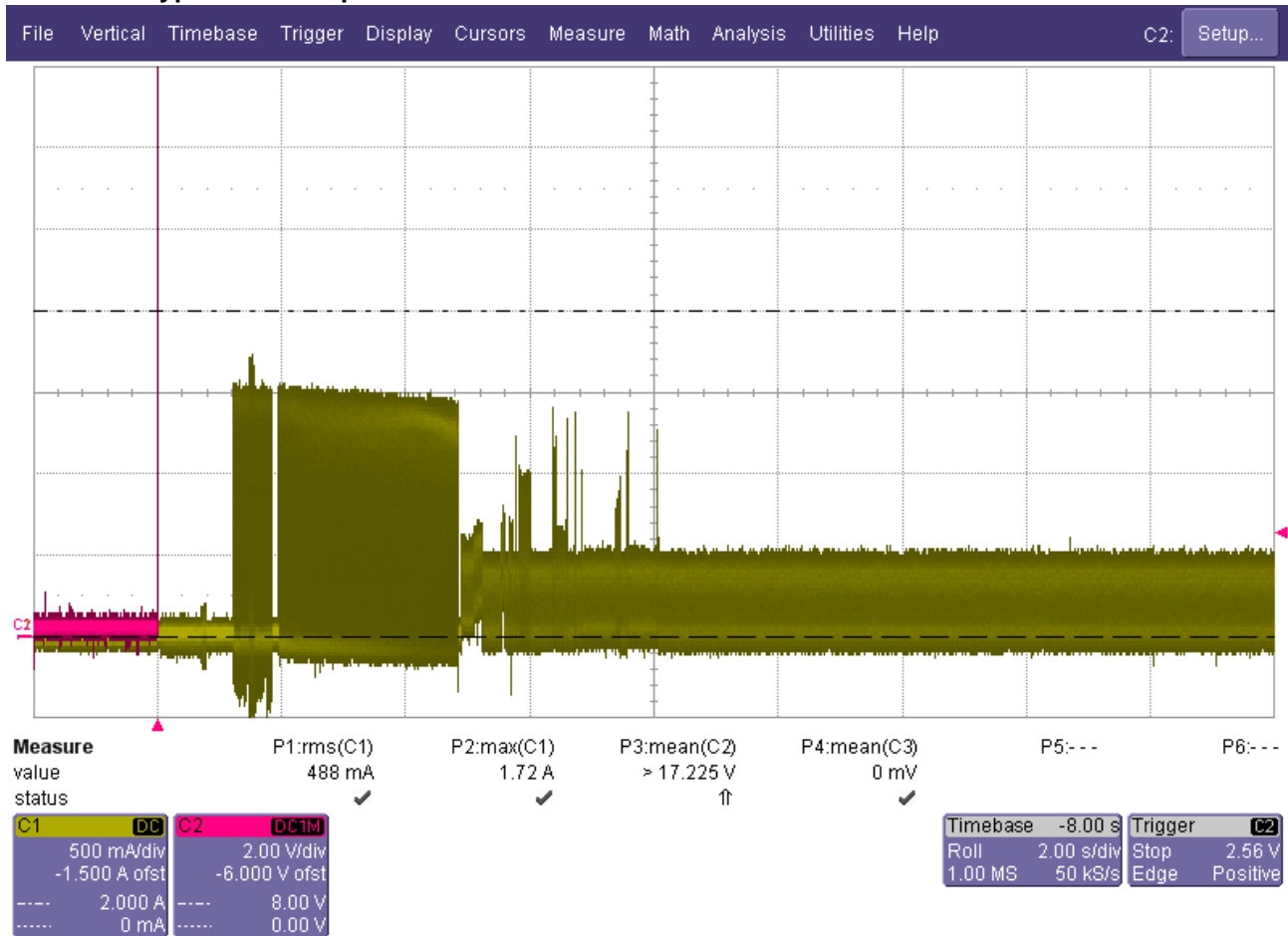

Note. Typical 12V startup and operation current profile (2 disk typical)

2.7.2 Conducted noise

Input noise ripple is measured at the host system power supply across an equivalent 80-ohm resistive load on the +12 volt line or an equivalent 15-ohm resistive load on the +5 volt line.

- Using 12-volt power, the drive is expected to operate with a maximum of 120 mV peak-to-peak square-wave injected noise at up to 10 MHz.
- Using 5-volt power, the drive is expected to operate with a maximum of 100 mV peak-to-peak square-wave injected noise at up to 10 MHz.

Note. Equivalent resistance is calculated by dividing the nominal voltage by the typical RMS read/write current.

2.7.3 Voltage tolerance

Voltage tolerance (including noise):

- 5V +10% / -7.5%
- 12V +10% / -7.5%

2.7.4 Power-management modes

The drive provides programmable power management to provide greater energy efficiency. In most systems, you can control power management through the system setup program. The drive features the following power-management modes:

Power modes	Heads	Spindle	Buffer
Active	Tracking	Rotating	Enabled
Idle	Tracking	Rotating	Enabled
Standby	Parked	Stopped	Enabled
Sleep	Parked	Stopped	Disabled

- **Active mode**

The drive is in Active mode during the read/write and seek operations.

- **Idle mode**

The buffer remains enabled, and the drive accepts all commands and returns to Active mode any time disc access is necessary.

- **Standby mode**

The drive enters Standby mode when the host sends a Standby Immediate command. If the host has set the standby timer, the drive can also enter Standby mode automatically after the drive has been inactive for a specifiable length of time. The standby timer delay is established using a Standby or Idle command. In Standby mode, the drive buffer is enabled, the heads are parked and the spindle is at rest. The drive accepts all commands and returns to Active mode any time disc access is necessary.

- **Sleep mode**

The drive enters Sleep mode after receiving a Sleep command from the host. In Sleep mode, the drive buffer is disabled, the heads are parked and the spindle is at rest. The drive leaves Sleep mode after it receives a Hard Reset or Soft Reset from the host. After receiving a reset, the drive exits Sleep mode and enters Standby mode with all current translation parameters intact.

- **Idle and Standby timers**

Each time the drive performs an Active function (read, write or seek), the standby timer is reinitialized and begins counting down from its specified delay times to zero. If the standby timer reaches zero before any drive activity is required, the drive makes a transition to Standby mode. In both Idle and Standby mode, the drive accepts all commands and returns to Active mode when disc access is necessary.

2.8 Environmental specifications

2.8.1 Ambient temperature

Ambient temperature is defined as the temperature of the environment immediately surrounding the drive. Actual drive case temperature should not exceed 69°C (156°F) within the operating ambient conditions.

Operating:	0° to 60°C (32° to 140°F)
Nonoperating: *	–40° to 70°C (–40° to 158°F)

* See Section 2.11.1 for reliability projections.

2.8.2 Temperature gradient

Operating:	20°C per hour (68°F per hour max), without condensation
Nonoperating:	30°C per hour (86°F per hour max)

2.8.3 Humidity

2.8.3.1 Relative humidity

Operating:	5% to 95% noncondensing (30% per hour max)
Nonoperating:	5% to 95% noncondensing (30% per hour max)

2.8.3.2 Wet bulb temperature

Operating:	37.7°C (99.9°F max)
Nonoperating:	40°C (104°F max)

2.8.4 Altitude

Operating:	–60.96 m to 3,048 m (–200 ft. to 10,000+ ft.)
Nonoperating:	–60.96 m to 12,192 m (–200 ft. to 40,000+ ft.)

2.8.5 Shock

All shock specifications assume that the drive is mounted securely with the input shock applied at the drive mounting screws. Shock may be applied in the X, Y or Z axis.

2.8.5.1 Operating shock

These drives comply with the performance levels specified in this document when subjected to a maximum operating shock of 70 Gs based on half-sine shock pulses of 2 msec during read operations. Shocks should not be repeated more than two times per second.

2.8.5.2 Nonoperating shock

The nonoperating shock level that the drive can experience without incurring physical damage or degradation in performance when subsequently put into operation is 300 Gs based on a nonrepetitive half-sine shock pulse of 2 msec duration.

2.8.6 Vibration

All vibration specifications assume that the drive is mounted securely with the input vibration applied at the drive mounting screws. Vibration may be applied in the X, Y or Z axis.

2.8.6.1 Operating vibration

The maximum vibration levels that the drive may experience while meeting the performance standards specified in this document are specified below.

5–350 Hz	0.50 Gs
350–500 Hz	0.25 Gs

2.8.6.2 Nonoperating vibration

The maximum nonoperating vibration levels that the drive may experience without incurring physical damage or degradation in performance when subsequently put into operation are specified below.

5–350 Hz	5.0 Gs
350–500 Hz	2.0 Gs

2.9 Acoustics

Drive acoustics are measured as overall A-weighted acoustic sound power levels (no pure tones). All measurements are consistent with ISO document 7779. Sound power measurements are taken under essentially free-field conditions over a reflecting plane. For all tests, the drive is oriented with the cover facing upward.

Note. For seek mode tests, the drive is placed in seek mode only. The number of seeks per second is defined by the following equation:

$$(\text{Number of seeks per second} = 0.4 / (\text{average latency} + \text{average access time}))$$

Table 4: Drive A-weighted Sound Power Levels (SWL, BA)

	Idle ^[1]	Seek profile
2TB and 1.5TB model	2.5 bels (typ) 2.6 bels (max)	2.6 bels (typ) 2.8 bels (max)
1TB model	1.9 bels (typ) 2.1 bels (max)	2.0 bels (typ) 2.2 bels (max)

[1] During periods of drive idle, some offline activity may occur according to the S.M.A.R.T. specification, which may increase acoustic and power to operational levels.

2.9.1 Test for Prominent Discrete Tones (PDTs)

Seagate follows the ECMA-74 standards for measurement and identification of PDTs. An exception to this process is the use of the absolute threshold of hearing. Seagate uses this threshold curve (originated in ISO 389-7) to discern tone audibility and to compensate for the inaudible components of sound prior to computation of tone ratios according to Annex D of the ECMA-74 standards.

2.10 Electromagnetic immunity

When properly installed in a representative host system, the drive operates without errors or degradation in performance when subjected to the radio frequency (RF) environments defined in the following table:

Table 5: Radio frequency environments

Test	Description	Performance level	Reference standard
Electrostatic discharge	Contact, HCP, VCP: ± 4 kV; Air: ± 8 kV	B	EN 61000-4-2: 95
Radiated RF immunity	80 to 1,000 MHz, 3 V/m, 80% AM with 1 kHz sine 900 MHz, 3 V/m, 50% pulse modulation @ 200 Hz	A	EN 61000-4-3: 96 ENV 50204: 95
Electrical fast transient	± 1 kV on AC mains, ± 0.5 kV on external I/O	B	EN 61000-4-4: 95
Surge immunity	± 1 kV differential, ± 2 kV common, AC mains	B	EN 61000-4-5: 95
Conducted RF immunity	150 kHz to 80 MHz, 3 Vrms, 80% AM with 1 kHz sine	A	EN 61000-4-6: 97
Voltage dips, interrupts	0% open, 5 seconds 0% short, 5 seconds 40%, 0.10 seconds 70%, 0.01 seconds	C C C B	EN 61000-4-11: 94

2.11 Reliability

2.11.1 Annualized Failure Rate (AFR) and Mean Time Between Failures (MTBF)

The product shall achieve an Annualized Failure Rate (AFR) of 0.32% (MTBF of 0.75 million hours) when operated in an environment of ambient air temperatures of 25°C. Operation at temperatures outside the specifications in Section 2.8 may increase the product AFR (decrease MTBF). AFR and MTBF are population statistics that are not relevant to individual units.

AFR and MTBF specifications are based on the following assumptions for desktop personal computer environments:

- 2,400 power-on-hours per year.
- 50,000 average motor start/stop cycles per year.
- Operations at nominal voltages.
- Temperatures outside the specifications in Section 2.8 may reduce the product reliability.
- Normal I/O duty cycle for desktop personal computers. Operation at excessive I/O duty cycle may degrade product reliability.

The desktop personal computer environment of power-on-hours, temperature, and I/O duty cycle affect the product AFR and MTBF. The AFR and MTBF will be degraded if used in an enterprise application

Nonrecoverable read errors	1 per 10 ¹⁴ bits read, max
Annualized Failure Rate (AFR)	0.32% (nominal power, 25°C ambient temperature)
Contact start-stop cycles	50,000 cycles (at nominal voltage and temperature, with 60 cycles per hour and a 50% duty cycle)
Warranty	To determine the warranty for a specific drive, use a web browser to access the following web page: support.seagate.com/customer/warranty_validation.jsp From this page, click on the "Verify Your Warranty" link. You will be asked to provide the drive serial number, model number (or part number) and country of purchase. The system will display the warranty information for your drive.
Preventive maintenance	None required.

2.12 Agency certification

2.12.1 Safety certification

These products are certified to meet the requirements of UL60950-1, CSA60950-1 and EN60950 and so marked as to the certify agency.

2.12.2 Electromagnetic compatibility

Hard drives that display the CE mark comply with the European Union (EU) requirements specified in the Electromagnetic Compatibility Directive (2004/108/EC) as put into place 20 July 2007. Testing is performed to the levels specified by the product standards for Information Technology Equipment (ITE). Emission levels are defined by EN 55022, Class B and the immunity levels are defined by EN 55024.

Drives are tested in representative end-user systems. Although CE-marked Seagate drives comply with the directives when used in the test systems, we cannot guarantee that all systems will comply with the directives. The drive is designed for operation inside a properly designed enclosure, with properly shielded I/O cable (if necessary) and terminators on all unused I/O ports. Computer manufacturers and system integrators should confirm EMC compliance and provide CE marking for their products.

Korean RRL

If these drives have the Korean Communications Commission (KCC) logo, they comply with paragraph 1 of Article 11 of the Electromagnetic Compatibility control Regulation and meet the Electromagnetic Compatibility (EMC) Framework requirements of the Radio Research Laboratory (RRL) Communications Commission, Republic of Korea.

These drives have been tested and comply with the Electromagnetic Interference/Electromagnetic Susceptibility (EMI/EMS) for Class B products. Drives are tested in a representative, end-user system by a Korean-recognized lab.

- Family name: Barracuda LP Series
- Certificate number: STX-BarracudaLP (B)

Australian C-Tick (N176)

If these models have the C-Tick marking, they comply with the Australia/New Zealand Standard AS/NZ CISPR22 and meet the Electromagnetic Compatibility (EMC) Framework requirements of the Australian Communication Authority (ACA).

2.12.3 FCC verification

These drives are intended to be contained solely within a personal computer or similar enclosure (not attached as an external device). As such, each drive is considered to be a subassembly even when it is individually marketed to the customer. As a subassembly, no Federal Communications Commission verification or certification of the device is required.

Seagate has tested this device in enclosures as described above to ensure that the total assembly (enclosure, disc drive, motherboard, power supply, etc.) does comply with the limits for a Class B computing device, pursuant to Subpart J, Part 15 of the FCC rules. Operation with noncertified assemblies is likely to result in interference to radio and television reception.

Radio and television interference. This equipment generates and uses radio frequency energy and if not installed and used in strict accordance with the manufacturer's instructions, may cause interference to radio and television reception.

This equipment is designed to provide reasonable protection against such interference in a residential installation. However, there is no guarantee that interference will not occur in a particular installation. If this equipment does cause interference to radio or television, which can be determined by turning the equipment on and off, you are encouraged to try one or more of the following corrective measures:

- Reorient the receiving antenna.
- Move the device to one side or the other of the radio or TV.
- Move the device farther away from the radio or TV.
- Plug the computer into a different outlet so that the receiver and computer are on different branch outlets.

If necessary, you should consult your dealer or an experienced radio/television technician for additional suggestions. You may find helpful the following booklet prepared by the Federal Communications Commission: *How to Identify and Resolve Radio-Television Interference Problems*. This booklet is available from the Superintendent of Documents, U.S. Government Printing Office, Washington, DC 20402. Refer to publication number 004-000-00345-4.

2.13 Environmental protection

Seagate designs its products to meet environmental protection requirements worldwide, including regulations restricting certain chemical substances.

2.13.1 European Union Restriction of Hazardous Substances (RoHS) Directive

The European Union Restriction of Hazardous Substances (RoHS) Directive, restricts the presence of chemical substances, including Lead, Cadmium, Mercury, Hexavalent Chromium, PBB and PBDE, in electronic products, effective July 2006. This drive is manufactured with components and materials that comply with the RoHS Directive.

2.13.2 China Restriction of Hazardous Substances (RoHS) Directive 中国限制危险物品的指令

This product has an Environmental Protection Use Period (EPUP) of 20 years. The following table contains information mandated by China's "Marking Requirements for Control of Pollution Caused by Electronic Information Products" Standard.



该产品具有20年的环境保护使用周期（EPUP）。下表包含了中国“电子产品所导致的污染的控制的记号要求”所指定的信息。

Name of Parts 部件名称	Toxic or Hazardous Substances or Elements 有毒有害物质或元素					
	Lead 铅 (Pb)	Mercury 汞 (Hg)	Cadmium 镉 (Cd)	Hexavalent Chromium 六价铬 (Cr6+)	Polybrominated Diphenyl 多溴联苯 (PBB)	Polybrominated Diphenyl Ether 多溴二苯醚 (PBDE)
PCBA	X	O	O	O	O	O
HDA	X	O	O	O	O	O

"O" indicates the hazardous and toxic substance content of the part (at the homogenous material level) is lower than the threshold defined by the China RoHS MCV Standard.

“O”表示该部件（于同类物品程度上）所含的危险和有毒物质低于中国RoHS MCV标准所定义的门槛值。

"X" indicates the hazardous and toxic substance content of the part (at the homogenous material level) is over the threshold defined by the China RoHS MCV Standard.

“X”表示该部件（于同类物品程度上）所含的危险和有毒物质超出中国RoHS MCV标准所定义的门槛值。

2.14 Corrosive environment

Seagate electronic drive components pass accelerated corrosion testing equivalent to 10 years exposure to light industrial environments containing sulfurous gases, chlorine and nitric oxide, classes G and H per ASTM B845. However, this accelerated testing cannot duplicate every potential application environment. Users should use caution exposing any electronic components to uncontrolled chemical pollutants and corrosive chemicals as electronic drive component reliability can be affected by the installation environment. The silver, copper, nickel and gold films used in Seagate products are especially sensitive to the presence of sulfide, chloride, and nitrate contaminants. Sulfur is found to be the most damaging. In addition, electronic components should never be exposed to condensing water on the surface of the printed circuit board assembly (PCBA) or exposed to an ambient relative humidity greater than 95%. Materials used in cabinet fabrication, such as vulcanized rubber, that can outgas corrosive compounds should be minimized or eliminated. The useful life of any electronic equipment may be extended by replacing materials near circuitry with sulfide-free alternatives.

3.0 Configuring and mounting the drive

This section contains the specifications and instructions for configuring and mounting the drive.

3.1 Handling and static-discharge precautions

After unpacking, and before installation, the drive may be exposed to potential handling and electrostatic discharge (ESD) hazards. Observe the following standard handling and static-discharge precautions:

Caution:

- Before handling the drive, put on a grounded wrist strap, or ground yourself frequently by touching the metal chassis of a computer that is plugged into a grounded outlet. Wear a grounded wrist strap throughout the entire installation procedure.
- Handle the drive by its edges or frame *only*.
- The drive is extremely fragile—handle it with care. Do not press down on the drive top cover.
- Always rest the drive on a padded, antistatic surface until you mount it in the computer.
- Do not touch the connector pins or the printed circuit board.
- Do not remove the factory-installed labels from the drive or cover them with additional labels. Removal voids the warranty. Some factory-installed labels contain information needed to service the drive. Other labels are used to seal out dirt and contamination.

3.2 Configuring the drive

Each drive on the Serial ATA interface connects point-to-point with the Serial ATA host adapter. There is no master/slave relationship because each drive is considered a master in a point-to-point relationship. If two drives are attached on one Serial ATA host adapter, the host operating system views the two devices as if they were both “masters” on two separate ports. Both drives behave as if they are Device 0 (master) devices.

Serial ATA drives are designed for easy installation. It is usually not necessary to set any jumpers on the drive for proper operation; however, if you connect the drive and receive a “drive not detected” error, your SATA-equipped motherboard or host adapter may use a chipset that does not support SATA speed autonegotiation. If you have a motherboard or host adapter that does not support autonegotiation:

- Install a jumper as shown in Figure 1 below to limit the data transfer rate to 1.5 Gbits per second (and leave the drive connected to the SATA-equipped motherboard or host adapter that doesn't support autonegotiation) or
- Install a SATA host adapter that supports autonegotiation, leave the drive jumper block set to “Normal operation” (see Figure 1 below), and connect the drive to that adapter. This option has the benefit of not limiting the drive to a 1.5 Gbits/sec transfer rate.

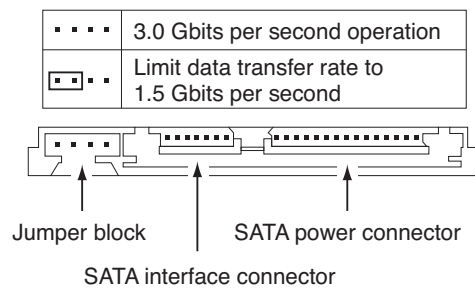

Figure 1. Serial ATA connectors

3.3 Serial ATA cables and connectors

The Serial ATA interface cable consists of four conductors in two differential pairs, plus three ground connections. The cable size may be 30 to 26 AWG with a maximum length of one meter (39.37 inches). See Table 6 for connector pin definitions. Either end of the SATA signal cable can be attached to the drive or host.

For direct backplane connection, the drive connectors are inserted directly into the host receptacle. The drive and the host receptacle incorporate features that enable the direct connection to be hot pluggable and blind mateable.

For installations which require cables, you can connect the drive as illustrated in Figure 2.

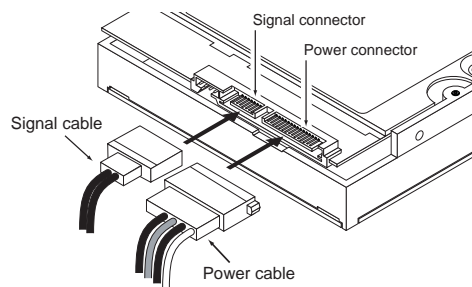

Figure 2. Attaching SATA cabling

Each cable is keyed to ensure correct orientation. Barracuda LP Series SATA drives support latching SATA connectors.

3.4 Drive mounting

You can mount the drive in any orientation using four screws in the side-mounting holes or four screws in the bottom-mounting holes. See Figure 3 for drive mounting dimensions. Follow these important mounting precautions when mounting the drive:

- Allow a minimum clearance of 0.030 inches (0.76 mm) around the entire perimeter of the drive for cooling.
- Use only 6-32 UNC mounting screws.
- The screws should be inserted no more than 0.150 inch (3.81 mm) into the bottom or side mounting holes.
- Do not overtighten the mounting screws (maximum torque: 6 inch-lb).

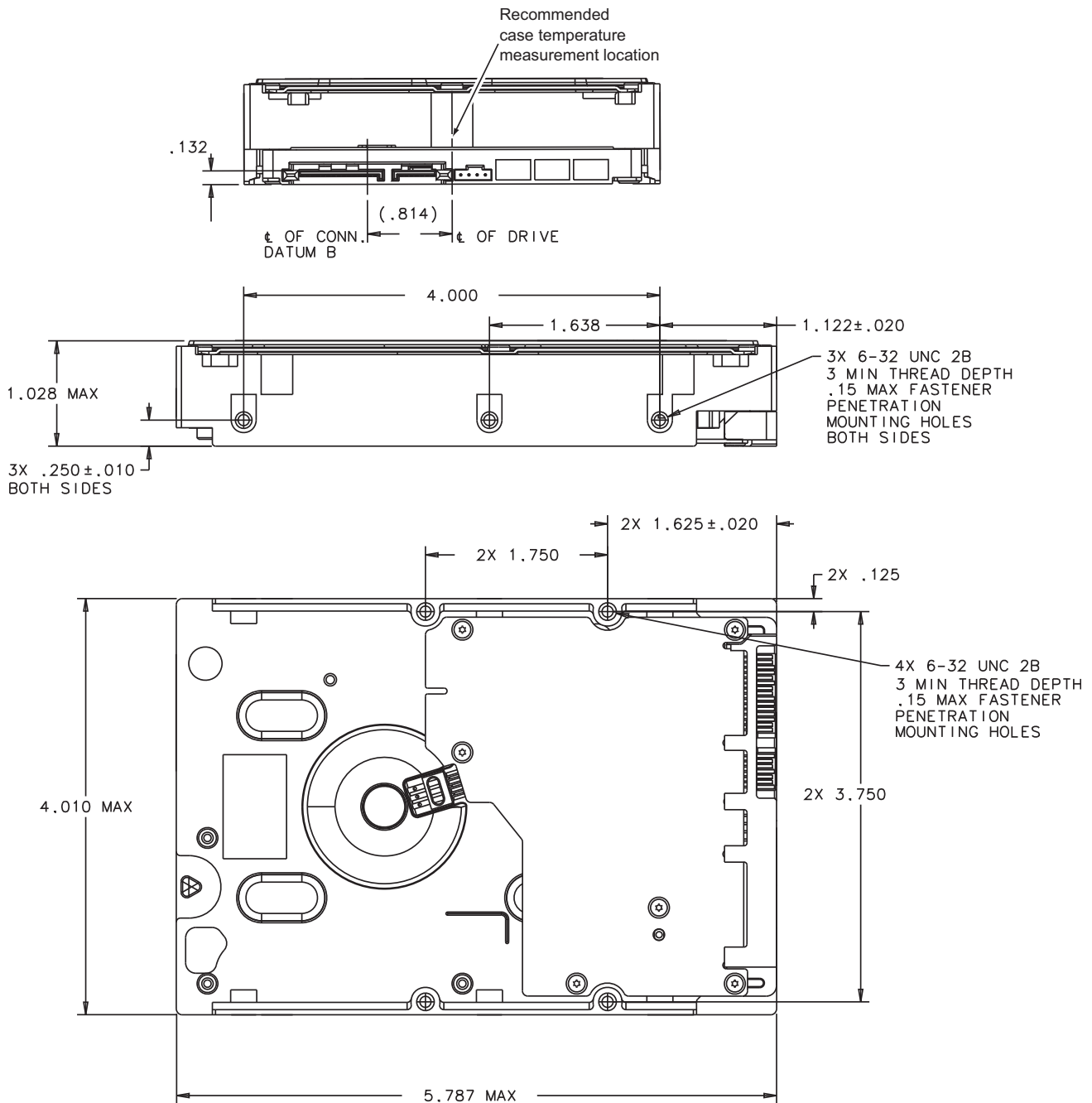

Figure 3. Mounting dimensions (2.0, 1.5 and 1.0 TB models)

4.0 Serial ATA (SATA) interface

These drives use the industry-standard Serial ATA interface that supports FIS data transfers. It supports ATA programmed input/output (PIO) modes 0–4; multiword DMA modes 0–2, and Ultra DMA modes 0–6.

For detailed information about the Serial ATA interface, refer to the “Serial ATA: High Speed Serialized AT Attachment” specification.

4.1 Hot-Plug compatibility

Barracuda LP Series SATA drives incorporate connectors which enable you to hot plug these drives in accordance with the Serial ATA Revision 2.6 specification. This specification can be downloaded from www.serial-ata.org.

4.2 Serial ATA device plug connector pin definitions

Table 6 summarizes the signals on the Serial ATA interface and power connectors.

Table 6: Serial ATA connector pin definitions

Segment	Pin	Function	Definition
Signal	S1	Ground	2nd mate
	S2	A+	Differential signal pair A from Phy
	S3	A-	
	S4	Ground	2nd mate
	S5	B-	Differential signal pair B from Phy
	S6	B+	
	S7	Ground	2nd mate

Key and spacing separate signal and power segments

Power	P1	V ₃₃	3.3V power
	P2	V ₃₃	3.3V power
	P3	V ₃₃	3.3V power, pre-charge, 2nd mate
	P4	Ground	1st mate
	P5	Ground	2nd mate
	P6	Ground	2nd mate
	P7	V ₅	5V power, pre-charge, 2nd mate
	P8	V ₅	5V power
	P9	V ₅	5V power
	P10	Ground	2nd mate
	P11	Ground or LED signal	If grounded, drive does not use deferred spin
	P12	Ground	1st mate.
	P13	V ₁₂	12V power, pre-charge, 2nd mate
	P14	V ₁₂	12V power
	P15	V ₁₂	12V power

Notes:

- All pins are in a single row, with a 1.27 mm (0.050") pitch.
- The comments on the mating sequence apply to the case of backplane blindmate connector only. In this case, the mating sequences are:
 - the ground pins P4 and P12.
 - the pre-charge power pins and the other ground pins.
 - the signal pins and the rest of the power pins.
- There are three power pins for each voltage. One pin from each voltage is used for pre-charge when installed in a blind-mate backplane configuration.
- All used voltage pins (V_x) must be terminated.

4.3 Supported ATA commands

The following table lists Serial ATA standard commands that the drive supports. For a detailed description of the ATA commands, refer to the Serial ATA International Organization: Serial ATA Revision 2.6 (<http://www.sata-io.org>).

See “S.M.A.R.T. commands” on page 32 for details and subcommands used in the S.M.A.R.T. implementation.

Table 7: Supported ATA commands

Command name	Command code (in hex)
Check Power Mode	E5 _H
Device Configuration Freeze Lock	B1 _H / C1 _H
Device Configuration Identify	B1 _H / C2 _H
Device Configuration Restore	B1 _H / C0 _H
Device Configuration Set	B1 _H / C3 _H
Device Reset	08 _H
Download Microcode	92 _H
Execute Device Diagnostics	90 _H
Flush Cache	E7 _H
Flush Cache Extended	EA _H
Format Track	50 _H
Identify Device	EC _H
Idle	E3 _H
Idle Immediate	E1 _H
Initialize Device Parameters	91 _H
Read Buffer	E4 _H
Read DMA	C8 _H
Read DMA Extended	25 _H
Read DMA Without Retries	C9 _H
Read Log Ext	2F _H
Read Multiple	C4 _H
Read Multiple Extended	29 _H
Read Native Max Address	F8 _H
Read Native Max Address Extended	27 _H
Read Sectors	20 _H
Read Sectors Extended	24 _H
Read Sectors Without Retries	21 _H
Read Verify Sectors	40 _H
Read Verify Sectors Extended	42 _H
Read Verify Sectors Without Retries	41 _H
Recalibrate	10 _H
Security Disable Password	F6 _H

Command name	Command code (in hex)
Security Erase Prepare	F3 _H
Security Erase Unit	F4 _H
Security Freeze	F5 _H
Security Set Password	F1 _H
Security Unlock	F2 _H
Seek	70 _H
Set Features	EF _H
Set Max Address Note: Individual Set Max Address commands are identified by the value placed in the Set Max Features register as defined to the right.	F9 _H Address: 00 _H Password: 01 _H Lock: 02 _H Unlock: 03 _H Freeze Lock: 04 _H
Set Max Address Extended	37 _H
Set Multiple Mode	C6 _H
Sleep	E6 _H
S.M.A.R.T. Disable Operations	B0 _H / D9 _H
S.M.A.R.T. Enable/Disable Autosave	B0 _H / D2 _H
S.M.A.R.T. Enable Operations	B0 _H / D8 _H
S.M.A.R.T. Execute Offline	B0 _H / D4 _H
S.M.A.R.T. Read Attribute Thresholds	B0 _H / D1 _H
S.M.A.R.T. Read Data	B0 _H / D0 _H
S.M.A.R.T. Read Log Sector	B0 _H / D5 _H
S.M.A.R.T. Return Status	B0 _H / DA _H
S.M.A.R.T. Save Attribute Values	B0 _H / D3 _H
S.M.A.R.T. Write Log Sector	B0 _H / D6 _H
Standby	E2 _H
Standby Immediate	E0 _H
Write Buffer	E8 _H
Write DMA	CA _H
Write DMA Extended	35 _H
Write DMA FUA Extended	CD _H
Write DMA Without Retries	CB _H
Write Log Extended	3F _H
Write Multiple	C5 _H
Write Multiple Extended	39 _H
Write Multiple FUA Extended	CE _H
Write Sectors	30 _H
Write Sectors Without Retries	31 _H
Write Sectors Extended	34 _H
Write Uncorrectable	45 _H

4.3.1 Identify Device command

The Identify Device command (command code EC_H) transfers information about the drive to the host following power up. The data is organized as a single 512-byte block of data, whose contents are shown in Table 7 on page 25. All reserved bits or words should be set to zero. Parameters listed with an “x” are drive-specific or vary with the state of the drive. See Section 2.0 on page 3 for default parameter settings.

The following commands contain drive-specific features that may not be included in the Serial ATA specification.

Word	Description	Value
0	Configuration information: • Bit 15: 0 = ATA; 1 = ATAPI • Bit 7: removable media • Bit 6: removable controller • Bit 0: reserved	0C5A _H
1	Number of logical cylinders	16,383
2	ATA-reserved	0000 _H
3	Number of logical heads	16
4	Retired	0000 _H
5	Retired	0000 _H
6	Number of logical sectors per logical track: 63	003F _H
7–9	Retired	0000 _H
10–19	Serial number: (20 ASCII characters, 0000 _H = none)	ASCII
20	Retired	0000 _H
21	Retired	0400 _H
22	Obsolete	0000 _H
23–26	Firmware revision (8 ASCII character string, padded with blanks to end of string)	x.xx
27–46	Drive model number: (40 ASCII characters, padded with blanks to end of string)	
47	(Bits 7–0) Maximum sectors per interrupt on Read multiple and Write multiple (16)	8010 _H
48	Reserved	0000 _H
49	Standard Standby timer, IORDY supported and may be disabled	2F00 _H
50	ATA-reserved	0000 _H
51	PIO data-transfer cycle timing mode	0200 _H
52	Retired	0200 _H
53	Words 54–58, 64–70 and 88 are valid	0007 _H
54	Number of current logical cylinders	xxxx _H
55	Number of current logical heads	xxxx _H
56	Number of current logical sectors per logical track	xxxx _H
57–58	Current capacity in sectors	xxxx _H
59	Number of sectors transferred during a Read Multiple or Write Multiple command	xxxx _H

Word	Description	Value
60–61	Total number of user-addressable LBA sectors available (see Section 2.1 for related information) *Note: The maximum value allowed in this field is: 0FFFFFFFh (268,435,455 sectors, 137 Gbytes). Drives with capacities over 137 Gbytes will have 0FFFFFFFh in this field and the actual number of user-addressable LBAs specified in words 100-103. This is required for drives that support the 48-bit addressing feature.	0FFFFFFFh*
62	Retired	0000 _H
63	Multiword DMA active and modes supported (see note following this table)	xx07 _H
64	Advanced PIO modes supported (modes 3 and 4 supported)	0003 _H
65	Minimum multiword DMA transfer cycle time per word (120 nsec)	0078 _H
66	Recommended multiword DMA transfer cycle time per word (120 nsec)	0078 _H
67	Minimum PIO cycle time without IORDY flow control (240 nsec)	00F0 _H
68	Minimum PIO cycle time with IORDY flow control (120 nsec)	0078 _H
69–74	ATA-reserved	0000 _H
75	Queue depth	001F _H
76	Serial ATA capabilities	xxxx _H
77	Reserved for future Serial ATA definition	xxxx _H
78	Serial ATA features supported	xxxx _H
79	Serial ATA features enabled	xxxx _H
80	Major version number	003E _H
81	Minor version number	0028 _H
82	Command sets supported	364B _H
83	Command sets supported	7C03 _H
84	Command sets support extension (see note following this table)	4003 _H See Word 108-111 note. (4003H = 0100000000000011 binary)
85	Command sets enabled	30xx _H
86	Command sets enabled	0001 _H
87	Command sets enable extension	4000 _H
88	Ultra DMA support and current mode (see note following this table)	xx3F _H
89	Security erase time	0000 _H
90	Enhanced security erase time	0000 _H
92	Master password revision code	FFFE _H
93	Hardware reset value	xxxx _H
95–99	ATA-reserved	0000 _H
100–103	Total number of user-addressable LBA sectors available (see Section 2.1 for related information). These words are required for drives that support the 48-bit addressing feature. Maximum value: 0000FFFFFFFFh.	ST32000542AS = 3,907,029,168 ST31500541AS = 2,930,277,168 ST31000520AS = 1,953,525,168
104–107	ATA-reserved	0000 _H

Word	Description	Value
108–111	The mandatory value of the world wide name (WWN) for the drive. NOTE: This field is valid if word 84, bit 8 is set to 1 indicating 64-bit WWN support.	Each drive will have a unique value.
112–127	ATA-reserved	0000 _H
128	Security status	0001 _H
129–159	Seagate-reserved	xxxx _H
160–254	ATA-reserved	0000 _H
255	Integrity word	xxA5 _H

Note. Advanced Power Management (APM) and Automatic Acoustic Management (AAM) features are not supported

Note. See the bit descriptions below for words 63, 84, and 88 of the Identify Drive data.

Description (if bit is set to 1)	
	Word 63
0	Multiword DMA mode 0 is supported.
1	Multiword DMA mode 1 is supported.
2	Multiword DMA mode 2 is supported.
8	Multiword DMA mode 0 is currently active.
9	Multiword DMA mode 1 is currently active.
10	Multiword DMA mode 2 is currently active.
	Word 84
0	SMART error login is supported.
1	SMART self-test is supported.
2	Media serial number is supported.
3	Media Card Pass Through Command feature set is supported.
4	Streaming feature set is supported.
5	GPL feature set is supported.
6	WRITE DMA FUA EXT and WRITE MULTIPLE FUA EXT commands are supported.
7	WRITE DMA QUEUED FUA EXT command is supported.
8	64-bit World Wide Name is supported.
9-10	Obsolete.
11-12	Reserved for TLC.
13	IDLE IMMEDIATE command with IUNLOAD feature is supported.
14	Shall be set to 1.
15	Shall be cleared to 0.

	Bit	Word 88
	0	Ultra DMA mode 0 is supported.
	1	Ultra DMA mode 1 is supported.
	2	Ultra DMA mode 2 is supported.
	3	Ultra DMA mode 3 is supported.
	4	Ultra DMA mode 4 is supported.
	5	Ultra DMA mode 5 is supported.
	6	Ultra DMA mode 6 is supported.
	8	Ultra DMA mode 0 is currently active.
	9	Ultra DMA mode 1 is currently active.
	10	Ultra DMA mode 2 is currently active.
	11	Ultra DMA mode 3 is currently active.
	12	Ultra DMA mode 4 is currently active.
	13	Ultra DMA mode 5 is currently active.
	14	Ultra DMA mode 6 is currently active.

4.3.2 Set Features command

This command controls the implementation of various features that the drive supports. When the drive receives this command, it sets BSY, checks the contents of the Features register, clears BSY and generates an interrupt. If the value in the register does not represent a feature that the drive supports, the command is aborted. Power-on default has the read look-ahead and write caching features enabled. The acceptable values for the Features register are defined as follows:

Table 8: Set Features command values

02 _H	Enable write cache (<i>default</i>).
03 _H	Set transfer mode (based on value in Sector Count register). Sector Count register values:
00 _H	Set PIO mode to default (PIO mode 2).
01 _H	Set PIO mode to default and disable IORDY (PIO mode 2).
08 _H	PIO mode 0
09 _H	PIO mode 1
0A _H	PIO mode 2
0B _H	PIO mode 3
0C _H	PIO mode 4 (<i>default</i>)
20 _H	Multiword DMA mode 0
21 _H	Multiword DMA mode 1
22 _H	Multiword DMA mode 2
40 _H	Ultra DMA mode 0
41 _H	Ultra DMA mode 1
42 _H	Ultra DMA mode 2
43 _H	Ultra DMA mode 3
44 _H	Ultra DMA mode 4
45 _H	Ultra DMA mode 5
46 _H	Ultra DMA mode 6
10 _H	Enable use of SATA features
55 _H	Disable read look-ahead (read cache) feature.
82 _H	Disable write cache
90 _H	Disable use of SATA features
AA _H	Enable read look-ahead (read cache) feature (<i>default</i>).
F1 _H	Report full capacity available

Note. At power-on, or after a hardware or software reset, the default values of the features are as indicated above.

4.3.3 S.M.A.R.T. commands

S.M.A.R.T. provides near-term failure prediction for disc drives. When S.M.A.R.T. is enabled, the drive monitors predetermined drive attributes that are susceptible to degradation over time. If self-monitoring determines that a failure is likely, S.M.A.R.T. makes a status report available to the host. Not all failures are predictable. S.M.A.R.T. predictability is limited to the attributes the drive can monitor. For more information on S.M.A.R.T. commands and implementation, see the *Draft ATA-5 Standard*.

SeaTools diagnostic software activates a built-in drive self-test (DST S.M.A.R.T. command for D4_H) that eliminates unnecessary drive returns. The diagnostic software ships with all new drives and is also available at: <http://seatools.seagate.com>.

This drive is shipped with S.M.A.R.T. features disabled. You must have a recent BIOS or software package that supports S.M.A.R.T. to enable this feature. The table below shows the S.M.A.R.T. command codes that the drive uses.

Table 9: S.M.A.R.T. commands

Code in features register	S.M.A.R.T. command
D0 _H	S.M.A.R.T. Read Data
D2 _H	S.M.A.R.T. Enable/Disable Attribute Autosave
D3 _H	S.M.A.R.T. Save Attribute Values
D4 _H	S.M.A.R.T. Execute Off-line Immediate (runs DST)
D5 _H	S.M.A.R.T. Read Log Sector
D6 _H	S.M.A.R.T. Write Log Sector
D8 _H	S.M.A.R.T. Enable Operations
D9 _H	S.M.A.R.T. Disable Operations
DA _H	S.M.A.R.T. Return Status

Note. If an appropriate code is not written to the Features Register, the command is aborted and 0x04 (abort) is written to the Error register.

5.0 Seagate Technology support services

Internet

For information regarding Seagate products and services, visit www.seagate.com.

Worldwide support is available 24 hours daily by e-mail for your questions.

Presales Support:

Presales@Seagate.com

Technical Support:

DiscSupport@Seagate.com

Warranty Support:

http://www.seagate.com/www/en-us/support/warranty_&_returns_assistance

mySeagate

my.seagate.com is the industry's first Web portal designed specifically for OEMs and distributors. It provides self-service access to critical applications, personalized content and the tools that allow our partners to manage their Seagate account functions. Submit pricing requests, orders and returns through a single, password-protected Web interface-anytime, anywhere in the world.

spp.seagate.com

spp.seagate.com supports Seagate resellers with product information, program benefits and sales tools. You may register for customized communications that are not available on the web. These communications contain product launch, EOL, pricing, promotions and other channel-related information. To learn more about the benefits or to register, go to spp.seagate.com, any time, from anywhere in the world.

Global Customer Support

Presales Support

Our Presales Support staff can help you determine which Seagate products are best suited for your specific application or computer system, as well as product availability and compatibility.

Technical Support

Seagate technical support is available to assist you online at support.seagate.com or through one of our call centers. Have your system configuration information and your "ST" model/product number available.

Customer Service Operations

Warranty Service

Seagate offers worldwide customer support for Seagate products. Seagate distributors, OEMs and other direct customers should contact their Seagate Customer Service Operations (CSO) representative for warranty-related issues. Resellers or end users of drive products should contact their place of purchase or Seagate warranty service for assistance. Have your serial number and model or part number available.

Data Recovery Services

Seagate offers data recovery services for all formats and all brands of storage media. Our data recovery services labs are currently located throughout the world. Additional information, including an online request form and data loss prevention resources, is available at <http://services.seagate.com/index.aspx>.

Authorized Service Centers

Seagate Service Centers are available on a global basis for the return of defective products. See www.seagate.com for the service center near you.

USA/Canada/Latin America support services

For an extensive list of telephone numbers to technical support, presales and warranty service in USA/Canada/Latin America, including business hours, go to the "Contact Us" page on www.seagate.com.

Global Customer Support

Presales, Technical, and Warranty Support

Call Center	Toll-free	Direct dial
USA, Canada, and Mexico	1-800-SEAGATE	+1-405-324-4700

Data Recovery Services

Call Center	Toll-free	Direct dial	FAX
USA, Canada, and Mexico	1-800-475-0143	+1-905-474-2162	1-800-475-0158 +1-905-474-2459

Europe, the Middle East and Africa Support Services

For an extensive list of telephone numbers to technical support, presales and warranty service in Europe, the Middle East and Africa, go to the "Contact Us" page on www.seagate.com.

Asia/Pacific Support Services

For an extensive list of telephone numbers to technical support, presales and warranty service in Asia/Pacific, go to the "Contact Us" page on www.seagate.com.

Index

A

- ACA 18
- acceleration 15
- acoustics 16
- Active 13
- Active mode 13
- AFR 17
- Agency certification 17
- altitude 14
- Ambient temperature 14
- ambient temperature 9, 10
- Annualized Failure Rate 17
- Annualized Failure Rate (AFR) 17
- areal density 8
- ATA commands 25
- Australia/New Zealand Standard AS/NZ CISPR22 18
- Australian Communication Authority (ACA) 18
- Australian C-Tick 18
- Average seek time 9

B

- buffer 9

C

- cables and connectors 21
- cache 9
- capacity 8
- case temperature 14
- CE mark 17
- certification 17
- Check Power Mode 25
- China RoHS directive 19
- compatibility 17
- Conducted noise 12
- Conducted RF immunity 16
- Configuring the drive 20
- connectors 21
- Corrosive environment 19
- CSA60950-1 17
- cycles 17
- Cylinders 8

D

- data-transfer rates 1
- DC power 10
- Default logical geometry 8
- density 8
- Device Configuration Freeze Lock 25
- Device Configuration Identify 25
- Device Configuration Restore 25
- Device Configuration Set 25

- Device Reset 25
- dimensions 22
- dissipation 11
- Download Microcode 25
- duty cycle 17

E

- Electrical fast transient 16
- Electromagnetic compatibility 17
- Electromagnetic Compatibility (EMC) 18
- Electromagnetic Compatibility control Regulation 18
- Electromagnetic Compatibility Directive (2004/108/EC) 17
- Electromagnetic immunity 16
- Electrostatic discharge 16
- electrostatic discharge (ESD) 20
- EN 55022, Class B 17
- EN 55024 17
- EN60950 17
- enclosures 18
- Environmental specifications 14
- error-correction algorithms 1
- errors 17
- ESD 20
- EU 17
- EU RoHS directive 19
- European Union (EU) requirements 17
- Execute Device Diagnostics 25

F

- FCC verification 18
- features 1
- Flush Cache 25
- Flush Cache Extended 25
- Format Track 25
- Formatted capacity 8

G

- geometry 8
- Gs 15
- guaranteed sectors 8

H

- Handling precautions 20
- heads 8
- height 9
- humidity 14

I

- I/O data-transfer rate 8
- I/O duty cycle 17
- Identify Device 25
- Identify Device command 27

Idle 13, 25
Idle Immediate 25
Idle mode 10, 13
Information Technology Equipment (ITE) 17
Initialize Device Parameters 25
Input noise ripple 12
input voltage 10
interface 8, 23
interference 18
internal data-transfer rate OD 8
is 9
ISO document 7779 16
ITE 17

K

KCC 18
Korean Communications Commission 18
Korean RRL 18

L

LBA mode 8
length 9
logical geometry 8

M

maintenance 17
master/slave 2
Mean Time Between Failures 17
mounting 22
mounting screws 15
mounting the drive 20
MTBF 17

N

noise 12
nominal power 9
Nonoperating shock 15
Nonoperating vibration 15
Nonrecoverable read errors 17

O

operating 11
Operating power 10
Operating shock 15
Operating vibration 15

P

Physical characteristics 9
point-to-point 2, 21
Power consumption 10
power dissipation 11
Power modes 13

Power specifications 10
Power-management modes 13
Power-on to Ready 9
power-on-hours 17
precautions 20
printed circuit board 20
programmable power management 13
prominent discrete tone 16

Q

quick reference 3

R

Radiated RF immunity 16
radio and television interference 18
radio frequency (RF) 16
random seeks 10
Read Buffer 25
Read DMA 25
Read DMA Extended 25
Read DMA without Retries 25
read errors 17
Read Log Ext 25
Read Multiple 25
Read Multiple Extended 25
Read Native Max Address 25
Read Native Max Address Extended 25
Read Sectors 25
Read Sectors Extended 25
Read Sectors Without Retries 25
Read Verify Sectors 25
Read Verify Sectors Extended 25
Read Verify Sectors Without Retries 25
Read/write heads 8
Read/write power 10
Recalibrate 25
recording density 8
recording method 8
Recording technology 8
relative humidity 14
Reliability 17
RF 16
RMS read/write current 12
RoHS 19
RRL 18

S

S.M.A.R.T. Disable Operations 26
S.M.A.R.T. Enable Operations 26
S.M.A.R.T. Enable/Disable Autosave 26
S.M.A.R.T. Execute Offline 26
S.M.A.R.T. implementation 25
S.M.A.R.T. Read Attribute Thresholds 26
S.M.A.R.T. Read Data 26

- S.M.A.R.T. Read Log Sector 26
- S.M.A.R.T. Return Status 26
- S.M.A.R.T. Save Attribute Values 26
- S.M.A.R.T. Write Log sector 26
- Safety certification 17
- SATA 23
- screws 15
- sectors 8
- Sectors per track 8
- Security Disable Password 25
- Security Erase Prepare 26
- Security Erase Unit 26
- Security Freeze 26
- Security Set Password 26
- Security Unlock 26
- See "S.M.A.R.T. commands" on page 34 25
- Seek 26
- Seek time 9
- Serial ATA (SATA) interface 23
- serial ATA ports 2
- servo electronics 10
- Set Features 26
- Set Max Address 26
- Set Max Address Extended 26
- Set Multiple Mode 26
- Shock 15
- single-track seeks 9
- Sleep 11, 13, 26
- Sleep mode 13
- sound 16
- Specification summary table 3
- spindle speed 8
- Spinup 11
- Spinup power 10
- Standby 11, 13, 26
- Standby Immediate 26
- Standby mode 10, 13
- standby timer 13
- Standby to Ready 9
- Start/stop times 9
- start-stop cycles 17
- static-discharge 20
- subassembly 18
- support services 33
- Surge immunity 16

T

- technical support services 33
- temperature 9, 14
- temperature gradient 14
- timer 13
- timers 13
- track density 8
- Track-to-track 9
- Track-to-track seek time 9

U

- UL60950-1 17

V

- Vibration 15
- voltage 10
- Voltage dips, interrupts 16
- Voltage tolerance 12

W

- Warranty 17
- weight 9
- wet bulb temperature 14
- width 9
- Write Buffer 26
- Write DMA 26
- Write DMA Extended 26
- Write DMA FUA Extended 26
- Write DMA Without Retries 26
- Write Log Extended 26
- Write Multiple 26
- Write Multiple Extended 26
- Write Multiple FUA Extended 26
- Write Sectors 26
- Write Sectors Extended 26
- Write Sectors Without Retries 26
- Write Uncorrectable 26



Seagate Technology LLC
920 Disc Drive, Scotts Valley, California 95066-4544, USA
Publication Number: 100564361, Rev. C , Printed in U.S.A.